



## Festoon System

Mobile Electrification System

Catalogue

C-track, I-beam, Wire-rope Series



NANTE cable festoon system provide a safe, effective and economical way of supplying power to cranes, hoists and moving machinery travelling along fixed tracks. NANTE can offer the festoon system for C track, I beam, Angel Bar, Wire rope, Square Pipe etc.

Features:

- Safe and reliable
- Simple to install or modify
- Enclosed self cleaning track
- Minimum maintenance

### General

1. C-track
2. Joint
3. Hanger
4. End stop
5. End cap
6. Towing Trolley
7. Middle Trolley
8. End Trolley
9. Support Bracket
10. Cable
11. Steel Wire

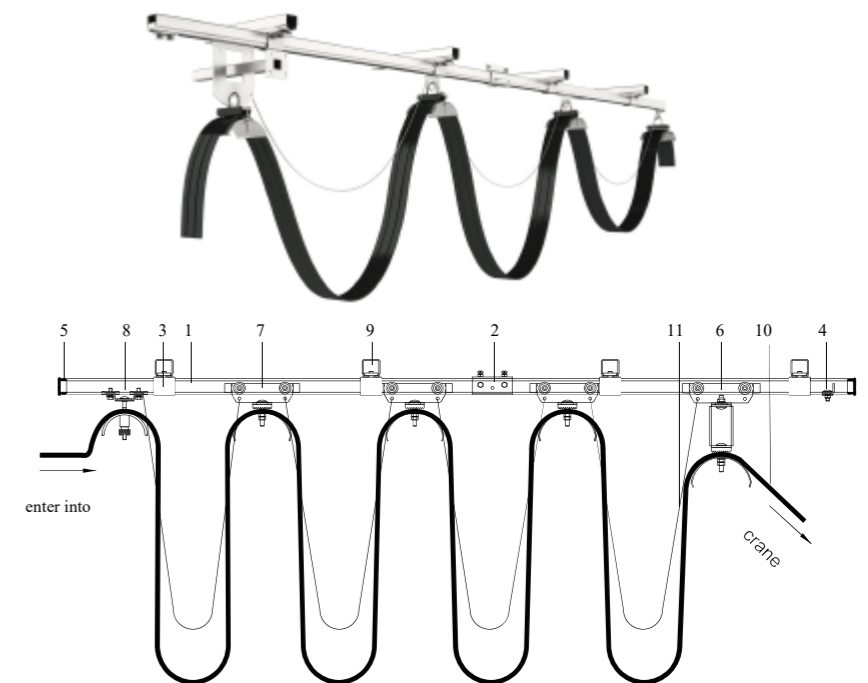

### Technical Data

Travel speed	< 120m/min
Temperature	-40°C -- +125°C
Cable load	< 120kg

Travel speed	Cable loop depth
max.35m/min	≥0.3m
35-50m/min	≤0.8m
50-80m/min	≥0.8m

C-track Festoon accessories - C-track  
C32/ C40/ C63

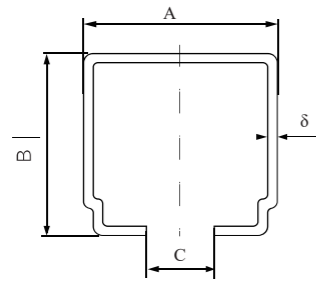

$L = n \times R/180^\circ$   
L is curve length,  
n is central angle,  
R is curved radius

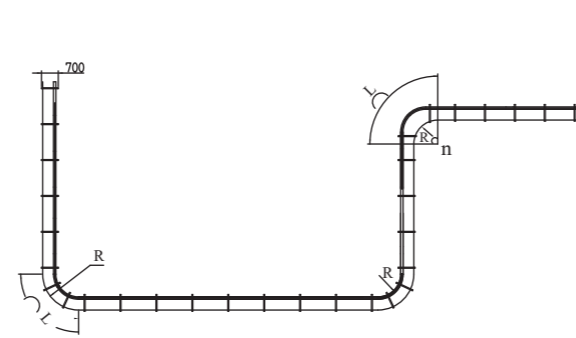

Type	Weight (kg/m)	A	B	C	δ
C32*30*1.5	1.19	32	30	12	1.5
C40*40*2.0	2.0	40	40	13	2.0
C63*63*4.0	5.98	63	63	18	18

Material: Galvanized Steel, 304#, 316# Stainless Steel  
(Nylon coating is optional for heavy corrosion environment)  
Curve  $R \geq 1.0m$ , only C32 can be curve



C-track Festoon Accessories - C32 Trolleys for Flat Cable  
C32TT-75/ C32MT-75

C32TT-75 - Towing trolley

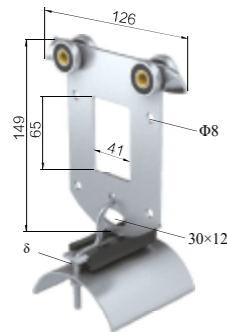

**Technical Feature**

Wheels: Ball bearing  
Max Travel Speed: 160m/min  
Material: Galvanized Steel + ABS  
Temperature:  $-30^\circ\text{C} \sim +100^\circ\text{C}$   
Max. Cable (mm): 75 W\* 32mm  
Max. Cable weight: 25kg  
Weight of Trolley: 0.59kg

C32MT-75 - Middle trolley

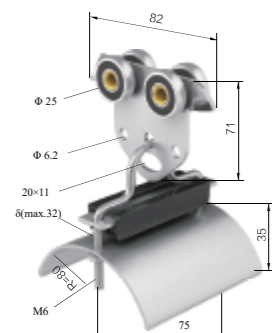

**Technical Feature**

Wheels: Ball bearing  
Max Travel Speed: 160m/min  
Material: Galvanized Steel + ABS  
Temperature:  $-30^\circ\text{C} \sim +100^\circ\text{C}$   
Max. Cable (mm): 75 W\* 32mm  
Max. Cable weight: 30kg  
Weight of Trolley: 0.41kg

C-track Festoon Accessories - C32 Trolley for Flat Cable  
C32TT-70/ C32MT-70 / C32ET

C32TT-70 - Towing trolley



\* can be Stainless Steel,  
Nylon coating is optional

**Technical Feature**

Wheels: Ball bearing  
Max Travel Speed: 120m/min  
Material: Galvanized Steel + ABS  
Temperature:  $-30^\circ\text{C} \sim +100^\circ\text{C}$   
Max. Cable (mm): 70 W\* 32mm  
Max. Cable weight: 22kg  
Weight of Trolley: 0.55kg

C32MT-70 - Middle trolley

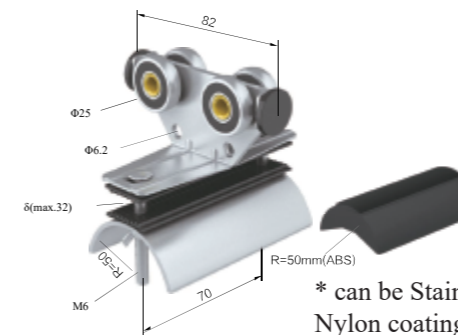

\* can be Stainless Steel,  
Nylon coating is optional

**Technical Feature**

Wheels: Ball bearing  
Max Travel Speed: 120m/min  
Material: Galvanized Steel + ABS  
Temperature:  $-30^\circ\text{C} \sim +100^\circ\text{C}$   
Max. Cable (mm): 70 W\* 32mm  
Max. Cable weight: 22kg  
Weight of Trolley: 0.32kg

C32ET- End trolley

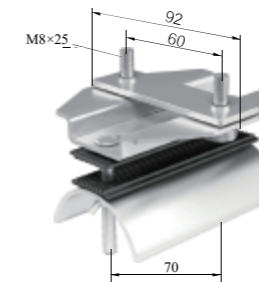

\* can be Stainless Steel,  
Nylon coating is optional

**Technical Feature**

Max Travel Speed: 120m/min  
Material: Galvanized Steel + ABS  
Temperature:  $-30^\circ\text{C} \sim +100^\circ\text{C}$   
Max. Cable (mm): 70 W\* 32mm  
Max. Cable weight: 25kg  
Weight of Trolley: 0.31kg

C-track Festoon Accessories - C32 Trolley for Flat Cable  
C32MT-60 Middle trolley

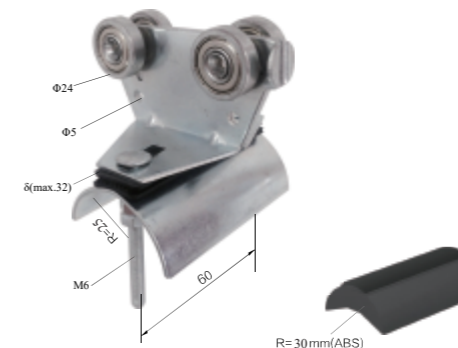

**Technical Feature**

Wheels: Bearing  
Max Travel Speed: 120m/min  
Material: Galvanized Steel + ABS  
Temperature:  $-30^\circ\text{C} \sim +100^\circ\text{C}$   
Max. Cable (mm): 60 W\* 32mm  
Max. Cable weight: 20kg  
Weight of Trolley: 0.32kg

C-track Festoon Accessories - C32 Plastic Middle Trolley  
C32PP-70 / C32RPP-30

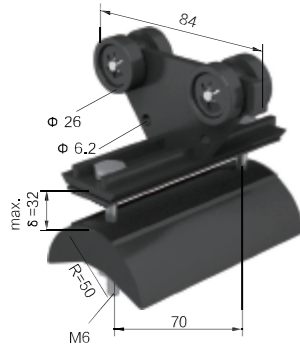

**Technical Feature**

Wheels: Nylon  
Max Travel Speed: 120m/min  
Material: --ABS  
Temperature: -30°C ~ +80°C  
Max. Cable (mm): 70 W\* 32mm  
Max. Cable weight: 8kg  
Weight of Trolley: 0.14kg

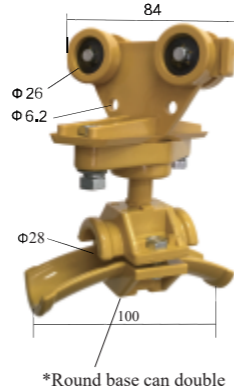

**Technical Feature**

Wheels: Nylon  
Max Travel Speed: 120m/min  
Material: Galvanized Steel + ABS  
Temperature: -30°C ~ +80°C  
Max. Cable (mm): φ28mm  
Max. Cable weight: 8kg  
Weight of Trolley: 0.15kg

C-track Festoon accessories - C32 Plastic Middle Trolley  
C32RMT

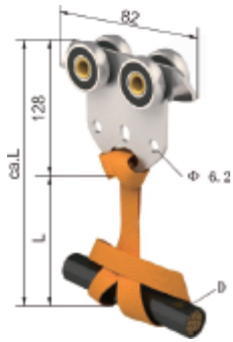

**Technical Feature**

Wheels: Ball bearing  
Max Travel Speed: 120m/min  
Material: Galvanized Steel + Nylon  
Temperature: -30°C ~ +100°C  
Max. Cable (mm): φ50mm / φ80mm / φ160mm  
Max. Cable weight: 22kg  
Weight of Trolley: 0.29kg

C-track Festoon Accessories - C32 Hanger  
C32HG-1/ C32HG-2/ C32HG-5

C32HG-1/ C32HG-2 for C-track support bracket

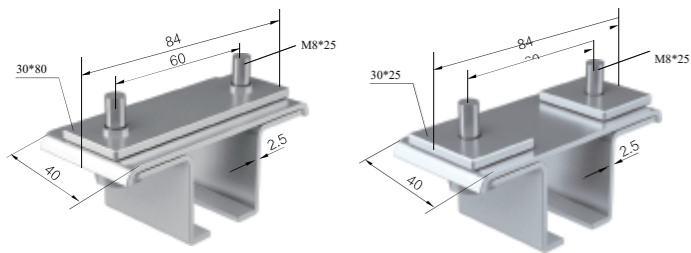

C32HG-5 for Angle steel support bracket

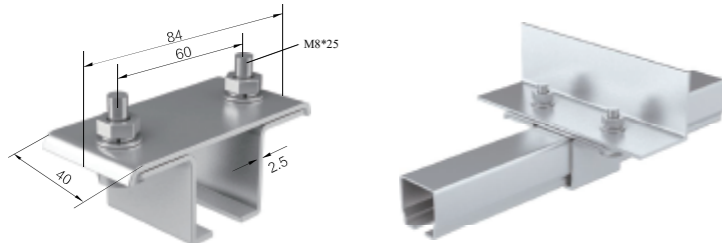

Type	Weight (kg)	Material
C32HG-1	0.22	Galvanized Steel
C32HG-2	0.22	Steel
C32HG-5	0.20	Steel

C-track Festoon Accessories - C32 Joints  
C32JS-2

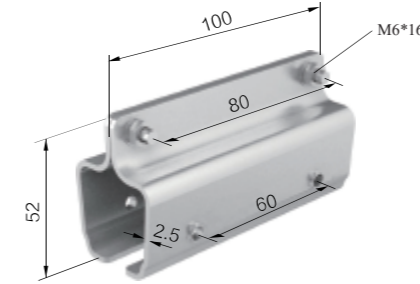

Type	Weight (kg)	Material
C32JS-2	0.27	Galvanized Steel

C-track Festoon Accessories - C32 End Cap  
C32EC



Type	Weight (kg)	Material
C32EC	0.005	Plastic

C-track Festoon Accessories - C32 End Stop  
C32ED

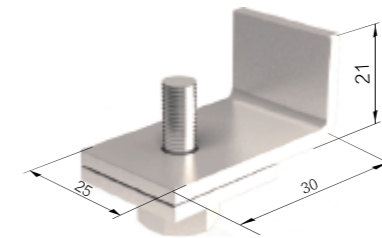

Type	Weight (kg)	Material
C32ED	0.05	Galvanized Steel

\*C32ED used for C32/C40 track



C-track Festoon accessories - C32 Cable Clip  
C32CP

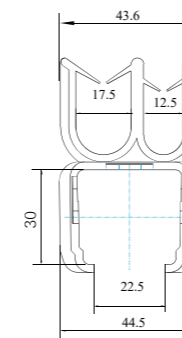

Type	Weight (kg)	Material
C32CP	0.02	Plastic

C-track Festoon Accessories - C32 Pendant Trolley for Flat Cable  
C32PT

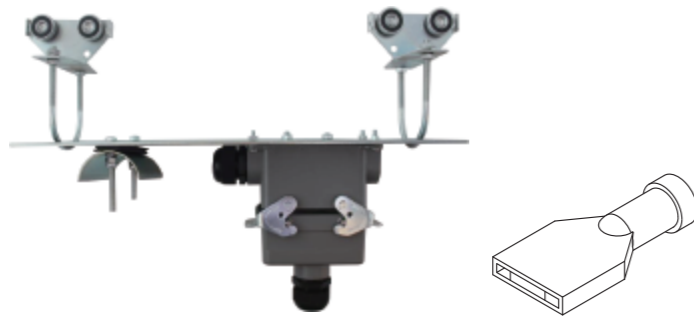

Type	Weight (kg)	Material
C32PT	2.5	Galvanized Steel

Can Customized with Flat Cable Gland

C-track Festoon Accessories - C40 Trolleys  
C40TT / C40MT / C40RMT

C40TT - Towing trolley

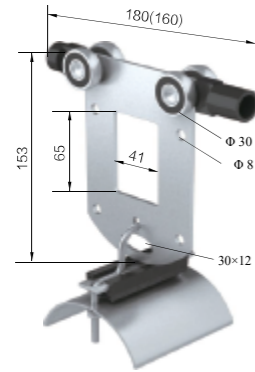

**Technical Feature**

Wheels: Ball bearing  
 Max Travel Speed: 160m/min  
 Material: Galvanized Steel + ABS  
 Temperature: -30°C ~ +100°C  
 Max. Cable (mm): 75 W\*32mm  
 Max. Cable weight: 35kg  
 Weight of Trolley: 0.65kg

C40MT - Middle trolley

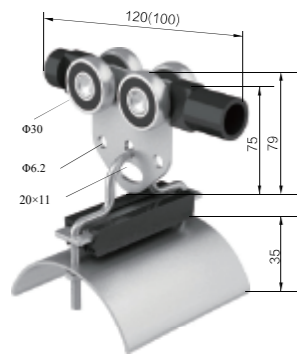

**Technical Feature**

Wheels: Ball bearing  
 Max Travel Speed: 160m/min  
 Material: Galvanized Steel + ABS  
 Temperature: -30°C ~ +100°C  
 Max. Cable (mm): 75 W\*32mm  
 Max. Cable weight: 30kg  
 Weight of Trolley: 0.52kg

C40RMT - Plastic middle trolley

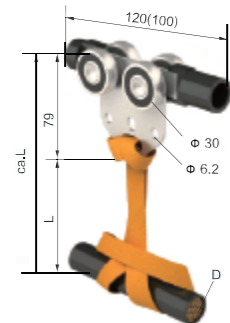

**Technical Feature**

Wheels: Ball bearing  
 Max Travel Speed: 100m/min  
 Material: Galvanized Steel + Nylon  
 Temperature: -30°C ~ +100°C  
 Max. Cable (mm): φ50mm / φ80mm / φ160mm  
 Max. Cable weight: 28kg  
 Weight of Trolley: 0.33kg

C-track Festoon Accessories - C40 Hanger  
C40HG-1 / C40HG-2 / C40HG-5

C40HG-1 and C40HG-2 for C-track support bracket

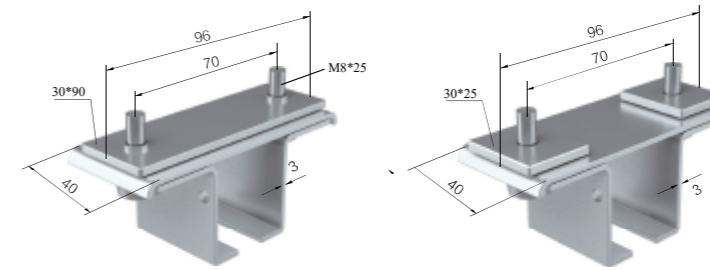

C40HG-5 for Angle steel support bracket

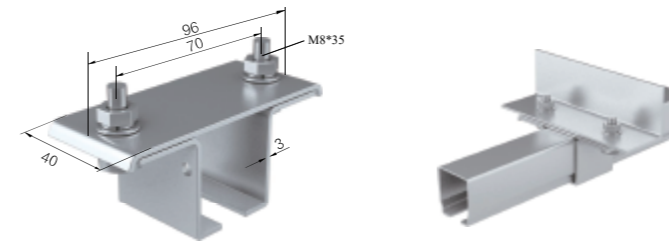

Type	Weight (kg)	Material
C40HG-1	0.30	Galvanized Steel
C40HG-2	0.30	
C40HG-5	0.22	

C-track Festoon Accessories - C40 Joints  
C40JS-2

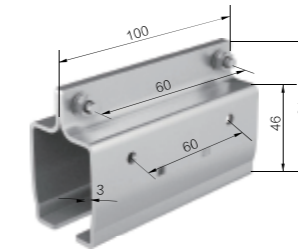

Type	Weight (kg)	Material
C40JS-2	0.32	Galvanized Steel

C-track Festoon Accessories - C40 End Cap  
C40EC

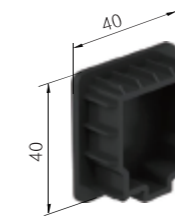

Type	Weight (kg)	Material
C40EC	0.01	Plastic

C-track Festoon Accessories - C40 Pendant Trolley for Flat Cable  
C40PT



Type	Weight (kg)	Material
C40PT	2.7	Galvanized Steel

Can Customized with Flat Cable Gland



C-track Festoon Accessories - C63 Trolleys for Flat Cable  
C63TT / C63MT/ C63ET

C63TT- Towing trolley

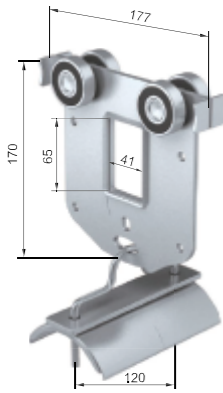

Technical Feature

Wheels: Ball bearing  
Max Travel Speed: 160m/min  
Material: Galvanized Steel  
Temperature: -30°C ~ +100°C  
Max. Cable (mm): 120 W\*40mm  
Max. Cable weight: 65kg  
Weight of Trolley: 2.3kg

C63MT - Middle trolley

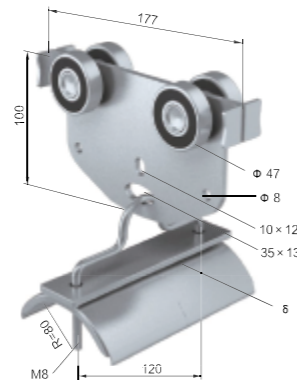

Technical Feature

Wheels: Ball bearing  
Max Travel Speed: 160m/min  
Material: Galvanized Steel  
Temperature: -30°C ~ +100°C  
Max. Cable (mm): 120 W\*40mm  
Max. Cable weight: 65kg  
Weight of Trolley: 1.95kg

C63ET - End trolley

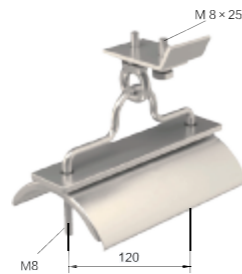

Technical Feature

Max Travel Speed: 160m/min  
Material: Galvanized Steel  
Temperature: -30°C ~ +100°C  
Max. Cable (mm): 120 W\*40mm  
Max. Cable weight: 65kg  
Weight of Trolley: 1.15kg

C-track Festoon Accessories - C40 Support Attachment  
C40SA-1 /C40SA-2

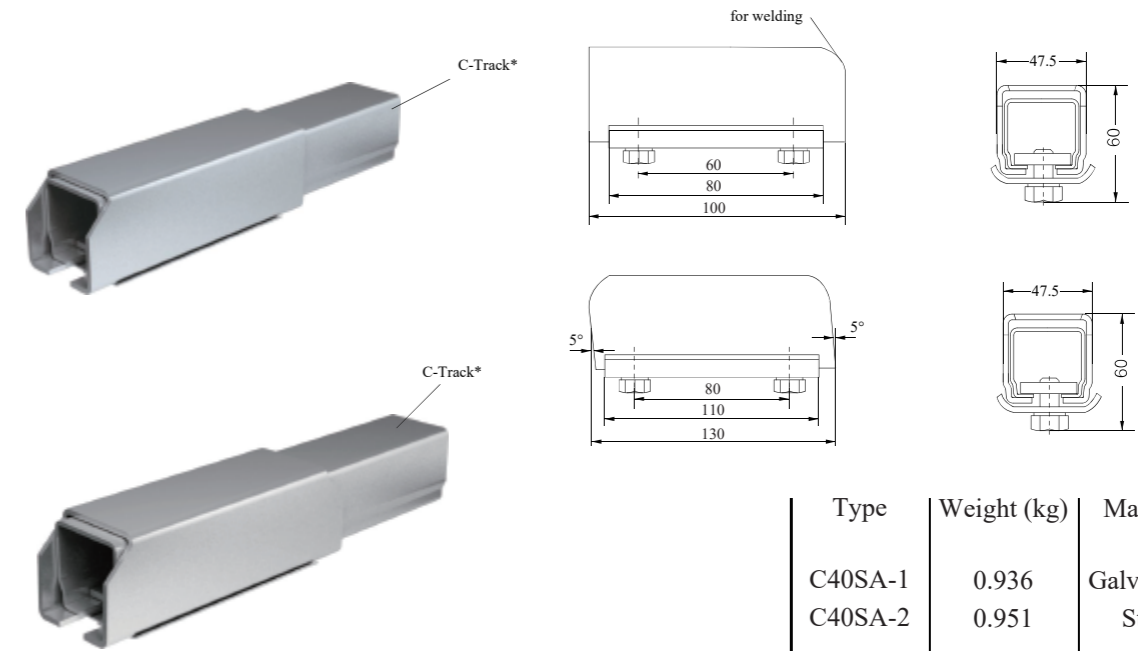

C-track Festoon Accessories - C-track Claw  
C32TC-1/ C40TC-1

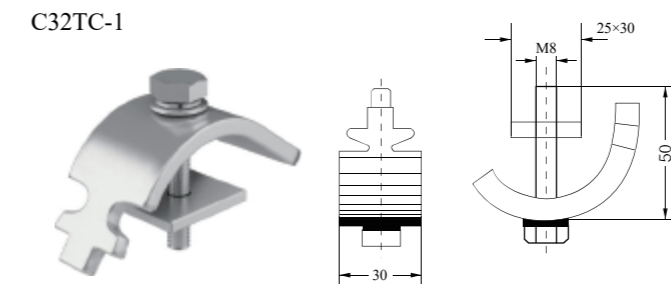

Be used for Standard Bracket

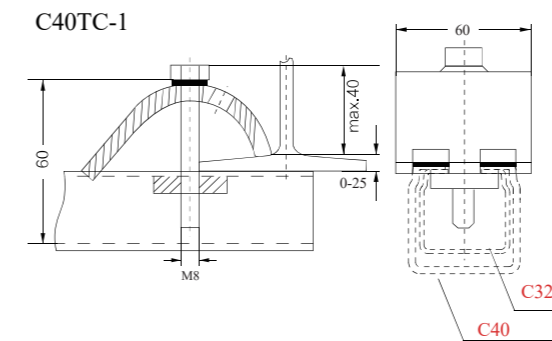

Be used for Heavy duty Bracket

Type	Weight (kg)	Material
C32TC-1	0.202	Galvanized Steel
C40TC-1	0.281	Steel

C-track Festoon Accessories - C63 Hanger  
C63HG

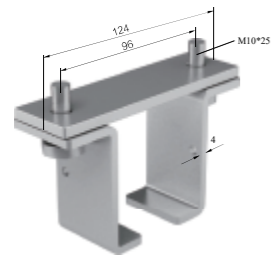

Type	Weight (kg)	Material
C63HG	0.45	Galvanized Steel

C-track Festoon Accessories - Joints  
C63JS

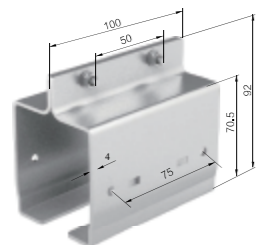

Type	Weight (kg)	Material
C63JS	0.72	Galvanized Steel

C-track Festoon Accessories - End Stop  
C63ED

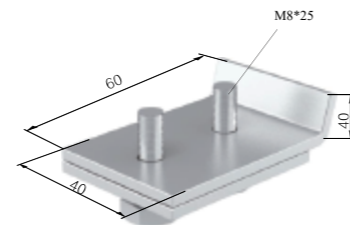

Type	Weight (kg)	Material
C63ED	0.72	Galvanized Steel

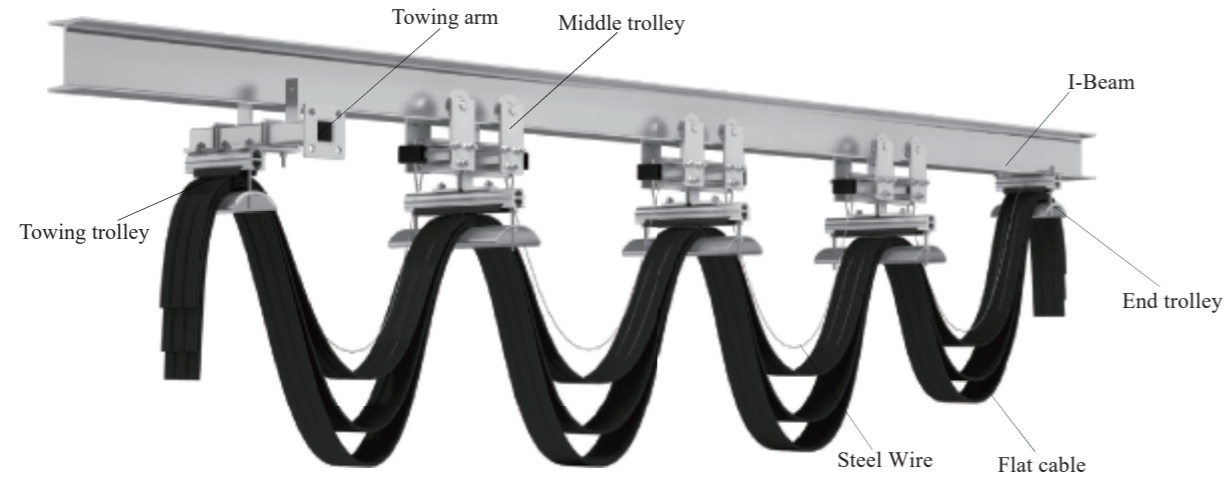

I-Beam Trolley  
N35MT series / N35MTL series / N35MTA series

N35MT series - Middle trolley

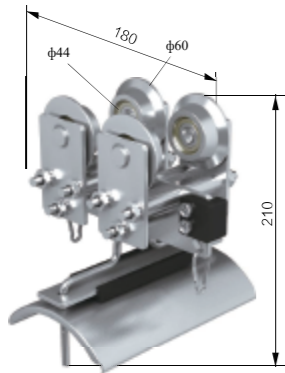

**Technical Feature**

Wheels: Ball bearing  
Max Travel Speed: 300m/min  
Material: Galvanized Steel + ABS  
Temperature: -30°C ~ + 120°C

N35MTL series - Middle trolley

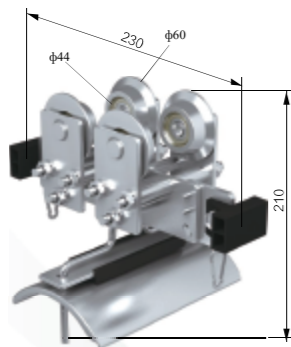

N35MTA series - Middle trolley

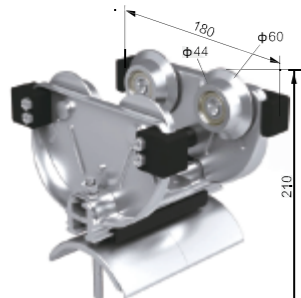

Type	Max.cable load	Dia. of Cable(mm)	Weight (kg)
N35MT-70	max.50kg/trolley	max.75 W × 32δ	1.90
N35MT-120	max.60kg/trolley	max.120 W × 60δ	2.40
N35MT-150	max.70kg/trolley	max.150 W × 70δ	2.50
N35MTL-120	max.50kg/trolley	max.120 W × 60δ	2.10
N35MTL-150	max.60kg/trolley	max.150 W × 70δ	2.60
N35MTL-250	max.120kg/trolley	max.250 W × 100δ	3.65
N35MTA-120	max.35kg/trolley	max.120 W × 50δ	2.20
N35MTA-150	max.40kg/trolley	max.150 W × 60δ	2.40

I-Beam Trolley  
N55MT series / N35TT-N55TT series / N35ET-N55ET series

N55MT series - Middle trolley

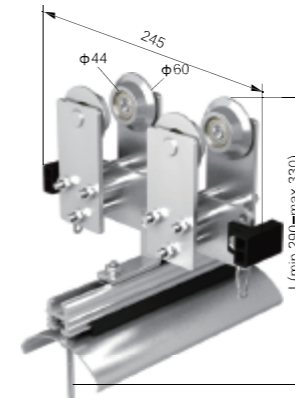

**Technical Feature**

Wheels: Ball bearing  
Max Travel Speed: 300m/min  
Material: Galvanized Steel + ABS  
Temperature: -30°C ~ + 120°C

N35TT / N55TT series - Towing trolley

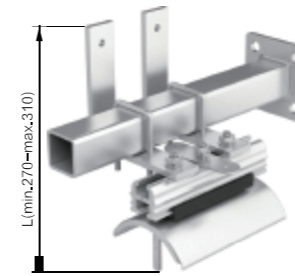

N35ET / N55ET series - End trolley

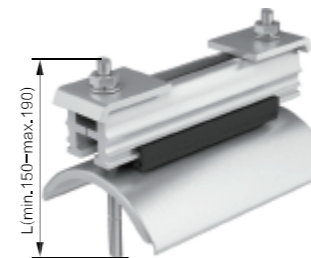

Type	Max.cable load	Dia. of Cable(mm)	Weight (kg)
N55MT-250	max.150kg/trolley	max.120 W × 50δ	4.35
N55MT-300	max.200kg/trolley	max.150 W × 50δ	4.75
N55MT-350	max.250kg/trolley	max.250 W × 70δ	5.15
N35TT-120	max.60kg/trolley	max.120 W × 50δ	2.1
N35TT-150	max.70kg/trolley	max.150 W × 50δ	2.30
N55TT-250	max.150kg/trolley	max.250 W × 70δ	2.60
N55TT-350	max.250kg/trolley	max.300 W × 70δ	3.00
N35ET-120	max.60kg/trolley	max.120 W × 50δ	1.25
N35ET-150	max.70kg/trolley	max.150 W × 50δ	1.45
N55ET-250	max.150kg/trolley	max.250 W × 70δ	1.95
N55ET-350	max.250kg/trolley	max.300 W × 70δ	2.35

I-Beam Trolley - for Round Cable  
N15RMT

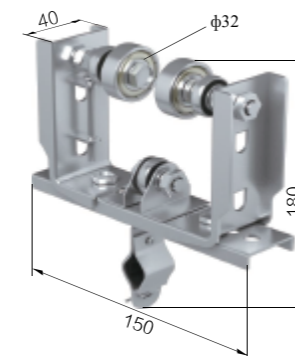

Type	Max.cable load	Dia. of Cable(mm)	Weight (kg)
N15RMT	max.5kg/trolley	D= φ 15mm	0.64

**I-Beam Trolley**  
N75MT-1 series / N75MT-2series / N75MT-1 series

**N75-1 - Middle trolley**

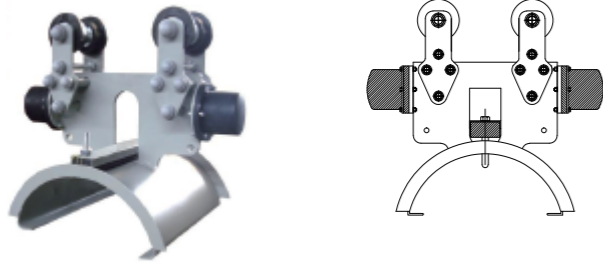

**Technical Feature**

Wheels: Ball bearing  
Max Travel Speed: 160m/min  
Material: Galvanized Steel + ABS  
Temperature: -30°C ~ +100°C  
Max. Cable weight: 200kg

**N75-2 - Middle trolley**

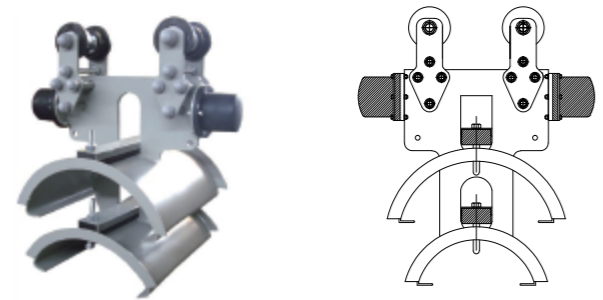

**Technical Feature**

Wheels: Ball bearing  
Max Travel Speed: 160m/min  
Material: Galvanized Steel + ABS  
Temperature: -30°C ~ +100°C  
Max. Cable weight: 200kg

**N75-3 - Middle trolley**

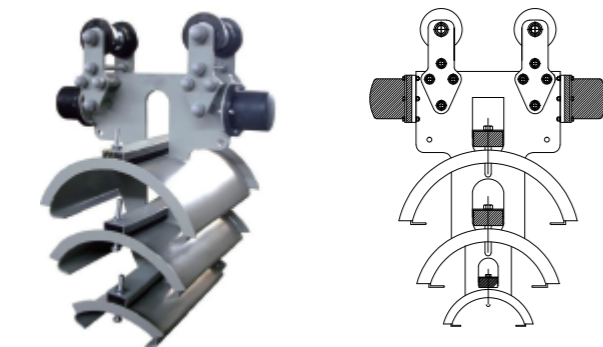

**Technical Feature**

Wheels: Ball bearing  
Max Travel Speed: 160m/min  
Material: Galvanized Steel + ABS  
Temperature: -30°C ~ +100°C  
Max. Cable weight: 200kg

**Wire Steel Festoon Accessories - for Round Cable**  
ST-12/14 & ST-14/16

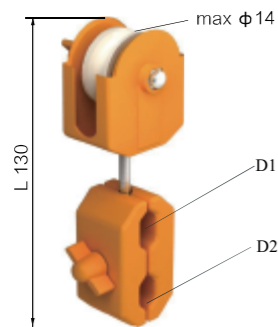

**Technical Feature**

Wheels: Plastic  
Max Travel Speed: 100m/min  
Material: Plastic  
Temperature: -30°C ~ +80°C

Type	Max.cable load	Dia. of Cable(mm)	Weight (kg)
ST-12/14	max.6kg/trolley	max.D1/D2= φ12mm/12mm	0.08
ST-14/16	max.7kg/trolley	max.D1/D2= φ12mm/12mm	0.09

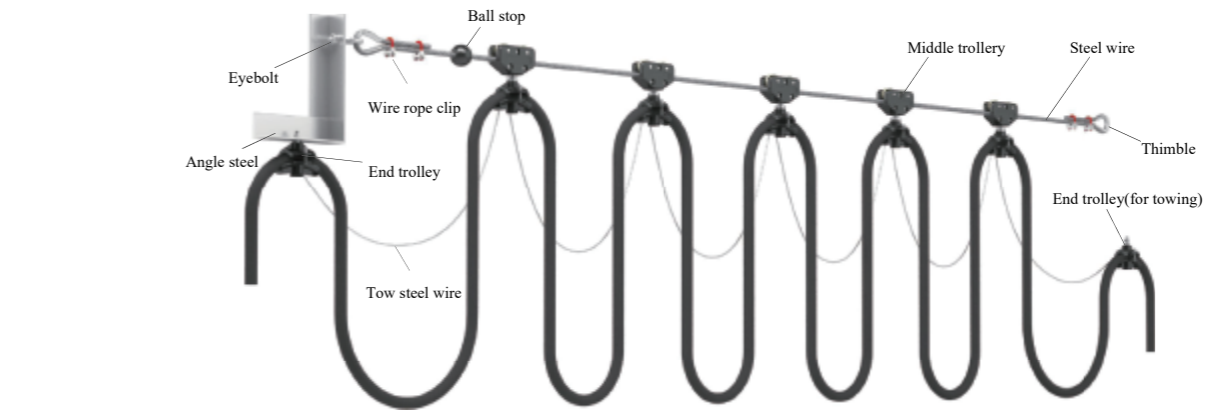

**Wire Steel Festoon Accessories - for Flat Cable**  
WFMT-70 / WFET-70

**Wire steel festoon system - Middle trolley**

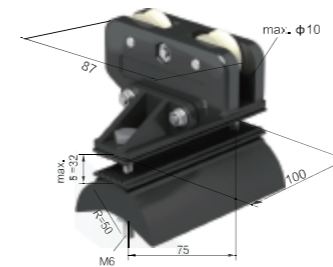

**Technical Feature**

Wheels: Plastic  
Max Travel Speed: 120m/min  
Material: ABS  
Temperature: -30°C ~ +80°C

**Wire steel festoon system - End trolley**

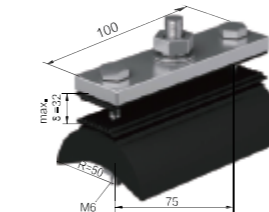

Type	Max.cable load	Dia. of Cable(mm)	Weight (kg)
WFMT-70	max.12kg/trolley	max.75 W × 50 δ	0.20
WFET-70	max.12kg/trolley	max.75 W × 50 δ	0.24

**Wire Steel Festoon Accessories - for Round Cable**  
WRMT-30 / WRMT-40/ WRET-30 / WRET-40

**Wire steel festoon system - Middle trolley**

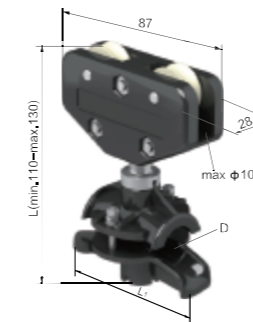

**Technical Feature**

Wheels: Plastic  
Max Travel Speed: 120m/min  
Material: ABS  
Temperature: -30°C ~ +80°C

**Wire steel festoon system - End trolley**

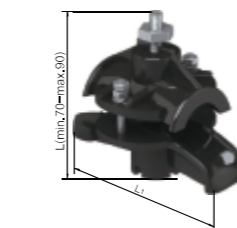

Type	Max.cable load	Dia. of Cable(mm)	Weight(kg)
WRMT-30	max.8kg/trolley	D= φ30mm	0.17
WRMT-40	max.10kg/trolley	D= φ40mm	0.18
WRET-30	max.8kg/trolley	D= φ30mm	0.06
WRET-40	max.10kg/trolley	D= φ40mm	0.07