



- Die-cast aluminum frame - lightweight, rugged, holds shafts and bearings in close alignment.
- Gearing - combination of precision cut, heat-treated helical and spur gears for quiet, efficient operation.
- Mechanical load brake - positive action, spring biased Weston type load brake holds the load and provides exact load spotting and control.
- Overload protection device protects against excessive overloads...clutch also acts at upper and lower limits.
- Multi-vane rotary air motor - eight vanes provide high torque smooth operation, positive starting and excellent control.
- Internal Muffler - reduces sound level.
- Pendant control - pendant throttle handle is of the full flow design for excellent load spotting capabilities.
- Throttle valve - precision throttle valves meter the air for smooth operation.

## Basic Hoist Data

### Rated Loads

1, 2, and 3-ton (Spark resistant models are rated at 1/2, 1 and 2-ton).

### Air Pressure Recommended

90 PSI

### Air Consumption

70 SCFM (full load-full speed) slow speed model;  
80 SCFM (full load-full speed) fast speed model.

### Pendant Control Hose

6 foot pendant hose standard for 10 foot lift hoist, longer hose assemblies up to 36 foot available.

### Lift

10 foot lifts are standard. Longer lifts are available.

### Net Weight (Basic Hoist)

100 lbs.

### Suspension

Hook or lug

### Air Inlet Size

3/4 NPTF

### Air Supply Hose Size

3/4 I.D. min.

## Hook & Lug Suspension Specifications

Capacity	Model	Hoist Catalog #	Full Load Lift Speed	Full Load Lowering Speed	Parts of Chain	Net Weight
tons			*FPM	*FPM		in
1/2	Hook / Spark	911683	16	22	1	95
	Lug / Spark	911693				110
1	Hook / Standard	911644	13	18	1	93
		911641	30	42		95
	Hook / Spark	911684	8	11	2	112
		911654	13	18		106
	Lug / Standard	911651	30	42	1	108
		911694	8	11		120
2	Hook / Standard	911645	6	9	2	110
		911642	15	12		112
	Hook / Spark	911685	5	7	3	146
		911655	6	9		116
	Lug / Standard	911652	15	21	2	118
		911695	5	7		170
3	Hook / Standard	911646	4	6	3	144
		911643	10	14		146
	Lug / Standard	911656	4	6		164
		911653	10	14		166

\*Hoist speeds based on 90 PSI line pressure with full rated hoist load

## Hook Suspension Specifications & Dimensions

Capacity	Model	Hoist Catalog #	A	B	C	D	E	H	X	Y
tons			in	in	in	in	in	in	in	in
1/2	Hook / Spark	911683	16-1/2	11-7/16	6-5/8	2-15/16	6-3/8	7/16	27-13/16	9-11/16
1	Hook / Standard	911644	16-1/2	11-17/16	6-5/8	2-15/16	6-3/8	7/16	27-13/16	9-11/16
		911641								
	Hook / Spark	911684	22	13-1/8	7-15/16	4-9/16	5-1/16	3/16	29-1/2	11
2	Hook / Standard	911645	22	13-1/8	7-15/16	4-9/16	5-1/16	3/16	29-1/2	11
		911642								
	Hook / Spark	911685	24-7/8	14-3/8	9-3/8	5-7/8	7-1/8	1/4	30-3/4	12
3	Hook / Standard	911646	24-7/8	14-3/8	9-3/8	5-7/8	7-1/8	1/4	30-3/4	12
		911643								

### Hook Suspension

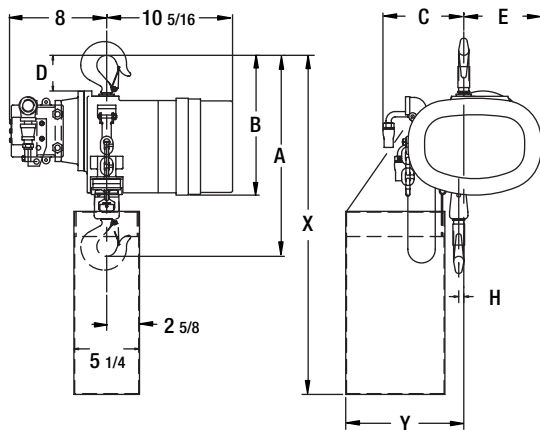

### Lug Suspension

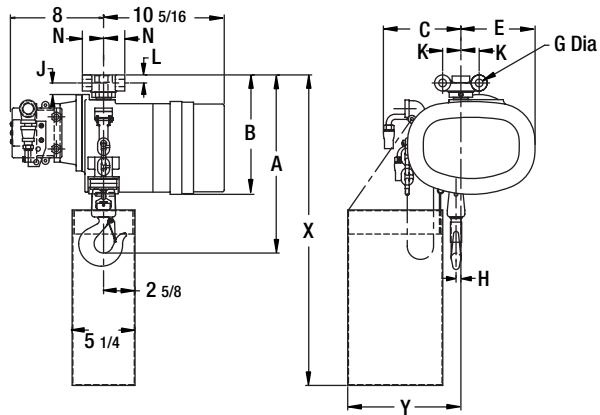

## Lug Suspension Specifications & Dimensions

Capacity	Model	Hoist Catalog #	B	C	E	J	K	L	M	N	G	H	X	Y
tons			in	in	in	in	in	in	in	in	in	in	in	in
1/2	Lug / Spark	911693	15-1/4	6-5/8	6-3/8	1	1-9/16	1-11/16	10-13/16	1-13/16	5/8	7/16	26-9/16	9-11/16
1	Lug / Standard	911654	15-1/4	6-5/8	6-3/8	1	1-9/16	1-11/16	10-13/16	1-13/16	5/8	7/16	26-9/16	9-11/16
		911651												
	Lug / Spark	911694	21	7-15/16	5-1/16	1-11/16	2-1/2	1-7/8	11-1/8	2-3/16	1	3/16	27-1/2	11
2	Lug / Standard	911655	21	7-15/16	5-1/16	1-11/16	2-1/2	1-7/8	11-1/8	2-3/16	1	3/16	27-1/2	11
		911652												
	Lug / Spark	911695	23-5/16	9-3/8	7-1/8	3-1/16	3	1-1/4	12-7/8	3	1-1/4	1/4	29-1/4	12
3	Lug / Standard	911656	23-5/16	9-3/8	7-1/8	3-1/16	3	1-1/4	12-7/8	3	1-1/4	1/4	29-1/4	12
		911653												

## Spark Resistant Models

Spark resistant hoists offer greater protection in hazardous environments. Components for spark resistance includes bronze alloy hooks with stainless steel hook latches, lower blocks of stainless steel on single part chain and aluminum on 2 and 3 part chain, chrome nickel non-magnetic stainless steel alloy load chain, bronze limit stop with aluminum limit actuators and modified sprocket and guide. A spark resistant chain container is recommended on 10 foot lift spark resistant hoists. Spark resistant chain containers are stainless steel.

The spark resistant KALC air hoists have lower speeds and are derated due to the use of stainless steel load chain. The lower wear life of stainless steel chain limits applications to medium-duty service.

When specifying lug suspended spark resistant hoists, care must be taken in the trolley selection to assure that the trolley fits the derated hoist lug. If this is your first purchase, consult the factory for assistance.